



Resilient Wedge Gate Valve

KENNEDY KS-FW FIG 8561 & 8068

AWWA C 509

Kennedy Gate Valves offer unique features and have been used in the water industry and in fire protection for over a century. Our Cast Iron Gate Valves also conform to AWWA C509. Inside our Gate Valve, the wedges used are completely encapsulated with EPDM rubber. The Gate Valve bodies, however, are epoxy coated. This allows the Gate Valve bodies to be unobstructed and free from air pockets, cavities, and depressions. The valves are available with NRS (non-rising stem) and OS&Y (outside-stem and yoke) configurations. Both configurations have similar features like ease of operation, positive sealing, and full flow capacity



General Specifications

Type : Resilient Seated Cast Iron
Gate Valves to AWWA C 509
SIZES : 2" to 12" Flanged
Working Pressure: 250 PSIG (17.20 bar)

Models

8561 : NRS Gate Valves
8068 : OS&Y Gate Valves, Flanged
8701 : Type 8561 with Post Plate

Flanges

ANSI B 16.1 Class 125 /150 FF
Options: Flanges Drilled to PN 16
Flange Face in RF / FF

Face to Face

ANSI B 16.10

Operation

Operating Nut, Hand Wheel
Indicator Post option available

Test Pressure

Seat Test: 400 PSI (27 Bar)
Body Hydraulic: 500 PSI (34 Bar)

Coating

Fusion bonded nontoxic epoxy coating NSF 61 Certified Meeting AWWA C-550 Standards.

UL/FM Approval

UL/FM Approved for 200 PSIG



MATERIAL OF CONSTRUCTION 8561 SS & 8068 A SS

Body & Bonnet	: Cast Iron ASTM A 126 Gr B	O Rings	: NBR
Wedge	: EPDM encapsulated Ductile Iron	Thrust Washers	: Bronze ASTM B 836 for OS&Y, Delrin for NRS
Stem & Stem Nut	: Copper Alloy ASTM B 584 C86700 (NRS) Copper Alloy ASTM B 16 C36000 (OS&Y)	Bonnet O Ring	: NBR
Stem Cap SQ Nut	: Grey Cast Iron ASTM A 126	Packing for OS&Y	: Lubricated Fiber
Hand wheel	: Grey Cast Iron ASTM a 126	Coating	: Fusion Bonded Epoxy 230 Microns)
		Bolt & Nuts	: Stainless Steel 304

Dimensions Resilient Seated Gate Valve KS FW

MODEL 8561, NON RISING STEM GATE TYPE

- 8561 ASS with Hand Wheel
- 8561 ANSS with 2" Square Stem Cap Nut
- 8701 ASS with 12" Dia Post Plate

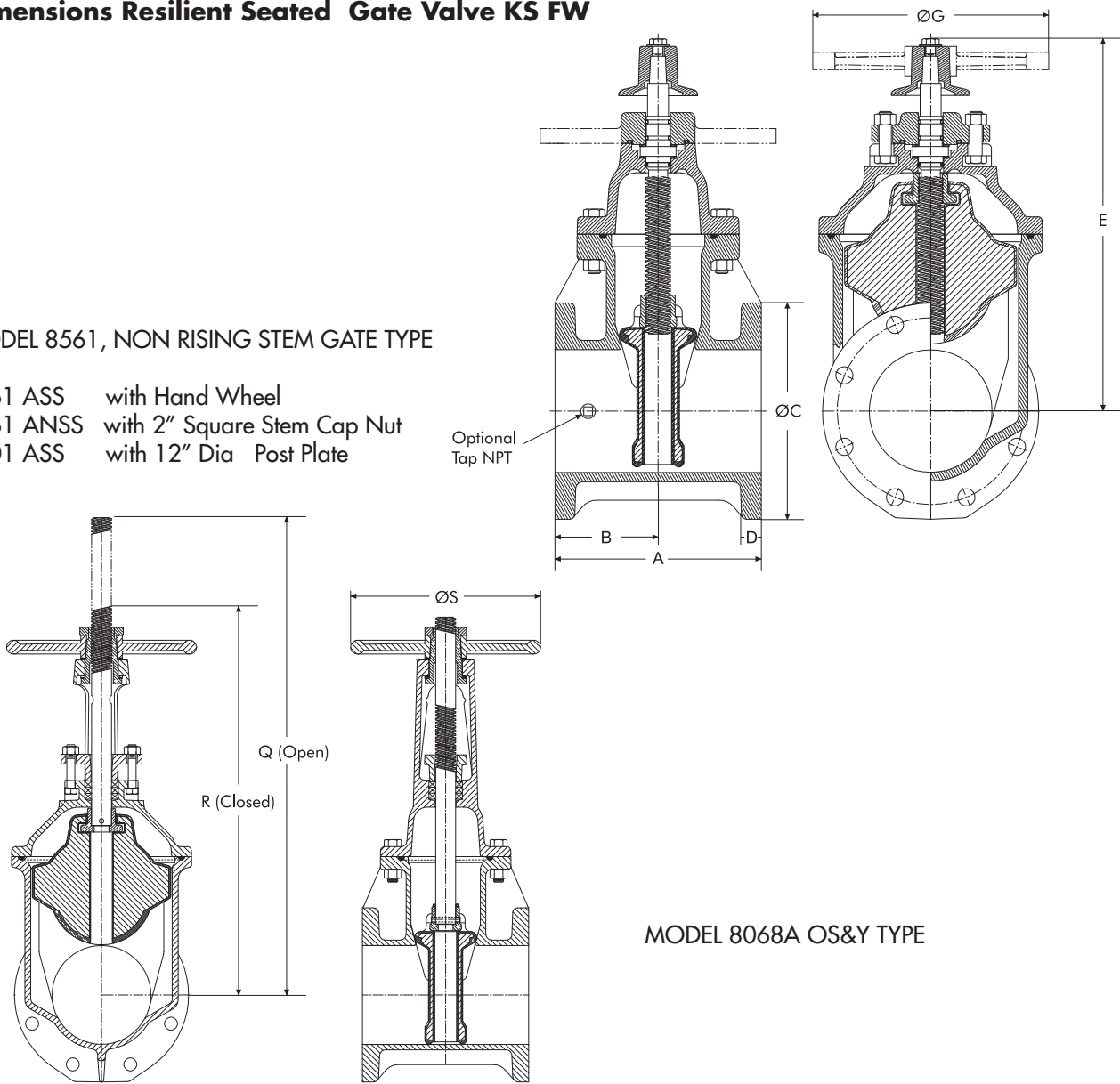

MODEL 8068A OS&Y TYPE

*Standard Flange Drilling ANSI B16.1 Class 125 / 150

SIZE in Inches	SIZE in mm	A	B	C	D	8561 NRS			8068 OS & Y			
						E	φG	Weight KG	Q	R	φS	Weight KG
2"	50	178	89	152	16	276	184	19	305	254	184	17
2 1/2"	65	190	95	178	17	289	184	23	416	352	184	23
3"	80	203	102	191	19	314	254	28	479	397	254	29
4"	100	229	114	229	24	375	254	45	603	464	254	48
6"	150	267	133	279	25	483	305	64	765	603	305	69
8"	200	292	146	343	29	572	356	108	959	743	356	115
10"	250	330	165	407	30	673	457	185	1162	899	457	194
12"	300	356	178	482	32	762	457	251	1349	1032	457	264

All dimensions in MM

Model 8701 is provided 309MM (12") Post plate suitable for mounting Kennedy Post indicator

The specifications and material grades shown are subject to revision without notice based on our product improvement programme.



Mcwane International, 1201 Vanderbilt Road, Birmingham AL 35234, USA
 Ph.: 205-716-6600, Fax: 205-324-7250 Email: inquiries@mcwaneintl.com
 www.mcwaneinternational.com



*Kennedy Valve USA is a division of McWane Inc.